



REFRIGERATION

SERVING THE FOOD INDUSTRY SINCE 1951

27" Refrigerated Prep Table with 5.65 Cu. Ft. and 1 Door

Item #: 24265

Model: PT-CN-0686



*High Performance
and Quality Refrigerated
Prep Table*

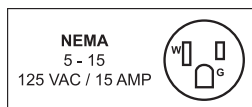

Authorized Dealer

REFRIGERATION

27" Refrigerated Prep Table with 5.65 Cu. Ft. and 1 Door



Detail Shots

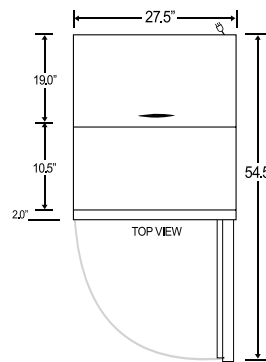
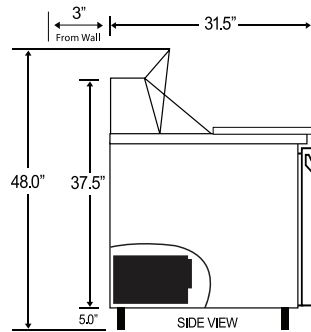
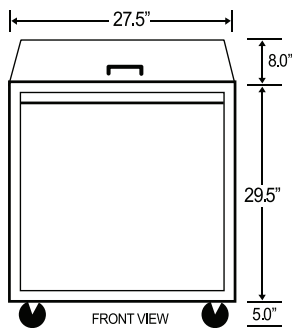

This refrigerated prep table provides ample storage space and a 3/4" cutting board / work area. Constructed of stainless steel and features self-closing doors

Features:

- 430 Stainless Steel exterior
- 304 Stainless Steel interior
- Removable door gasket
- European controller and compressor
- Plastic coated shelves.
- 3/4" thick cutting board
- The units automatically defrost
- Polyurethane insulation
- Self-closing doors
- Casters
- Mechanical temperature controller

PRODUCT SPECIFICATIONS

ITEM NUMBER	24265	COOLING SYSTEM	Ventilated
MODEL	PT-CN-0686	INSERT CAPACITY	six 1/6 pans two 1/9 pans
DESCRIPTION	27" Refrigerator	NUMBER OF DOORS	1
TEMPERATURE RANGE	0°C ~ 10°C 32°F ~ 50°F	NUMBER OF SHELVES	1
MAX AMBIENT TEMP RATING	90°F	SHELF CAPACITY	90 lbs.
HORSEPOWER	0.52 HP	EXTERIOR DIMENSIONS (WDH)	27" x 29.5" x 42.3"
PHASE	1	INTERIOR DIMENSIONS (WDH)	24" x 23.82" x 23.5"
ELECTRICAL	110 V / 60 Hz	PACKAGING DIMENSIONS	31.8" x 34" x 45.5"
AMPS	5.3	NET VOLUME (CU. FT.)	5.65 cu. ft.
REFRIGERANT	R134a	WEIGHT	176 lbs.
ISOLATION MATERIAL	R141b	PACKAGING WEIGHT	220 lbs.

OMCAN INC.

Telephone: 1-800-465-0234
 Fax: (905) 607-0234
 E-mail: sales@omcan.com
 Website: www.omcan.com



Follow us to keep up to date with the latest news and offers

